



MEC18

Mechanical exhaust control



READ AND SAVE THESE INSTRUCTIONS!

	Product information	Chapters 1 + 2
	Mechanical installation	Chapter 3
	Electrical installation	Chapter 4
	Start up and configuration	Chapter 5
	Maintenance and troubleshooting	Chapter 6

Job name: _____

Installer: _____

Installation date: _____

Distributor contact information:
exodraft a/s • Tel: +45 7010 2234
info@exodraft.dk • www.exodraft.com



Contents

1. Product Information	
1.1 Function	3
1.2 Shipping	3
2. Specifications	
2.1 Dimensions and capacities	4
3. Mechanical installation	
3.1 Location	5
3.2 Mounting of control	5
3.3 Mounting of transducer	6
3.4 Mounting of duct probe	6
3.5 Connecting transducer to duct probe	6
4. Electrical installation	
4.1 General	7
4.2 Continuous fan operation	8
4.3 Intermittent fan operation	9
4.4 Connection to a Variable Frequency Drive	11
4.5 Integrated with external PDS	12
5. Startup and configuration	
5.1 General	13
5.2 Setting operating pressure	14
6. Maintenance and troubleshooting	

Symbol legend

The following terms are used throughout this manual to bring attention to the presence of potential hazards or to important information concerning the product.



DANGER

Indicates an imminent hazardous situation which, if not avoided, will result in death, serious injury or substantial property damage.



CAUTION

Indicates an imminent hazardous situation which, if not avoided, may result in personal injury or property damage.



TO REDUCE THE RISK OF FIRE, ELECTRICAL SHOCK OR INJURY TO PERSONS, OBSERVE THE FOLLOWING:

1. Use this unit in the manner intended by the manufacturer. If you have questions, contact the manufacturer's distributor at the address or telephone number listed on the front of the manual.
2. Before servicing or cleaning the unit, switch off at service panel and lock service panel to prevent power from being switched on accidentally.
3. Installation work and electrical wiring must be done by a qualified person(s) in accordance with applicable codes and standards.
4. Follow the appliance manufacturer's guidelines and safety

standards and the national authorities safety standards in the country in which the installation is taking place.

5. This unit must be grounded.

How to use this manual

This installation manual does not contain any system design documentation. System design documentation is available from **exodraft**.

Accessories and variable frequency drives are not covered by this manual. Please refer to these component's individual manuals.

1. Product information

1.1 Function

Use The **exodraft** MEC18 is a Mechanical Exhaust Control used to monitor and maintain a constant pressure in a duct system. This is achieved by modulating the speed of a fan or ventilator. The MEC18 can be used with the **exodraft** models EFH, RSV and the EXHAUSTO models BESB and BESF. It can control the fan speed directly or via a Variable Frequency Drive (VFD). The MEC18 is typically used to control the pressure in duct systems serving clothes dryers, bathrooms, kitchen hoods and other building venting applications.

Function The control monitors the pressure in a duct system via connection to a pressure sensor (XTP) , and maintains the pressure by modulating the fan speed.
The control has an integrated safety system that assures the appliance shuts down in the event of fan and/or control failure.

The use of the MEC18 is not restricted to any type of duct or venting application. When the appliance is activated, the control sends maximum voltage to the fan or VFD. Once the specified pressure is achieved, the control regulates the voltage to the fan or VFD to maintain the specified pressure (the value can be viewed on the display).

If desired, the control can be interlocked with an appliance. When the appliance is activated, the control sends maximum voltage to the fan or VFD. Once the specified pressure is achieved, the control releases the appliance for operation and continues to regulate the voltage to the fan or VFD to maintain the specified pressure (the value can be viewed in the display). In the event of insufficient pressure, the control assures the appliance(s) shuts down after 15 seconds. When the appliance shuts down, the control turns off the fan.

The control can be used in one of two ways:

- Interlocked with the appliance to pre-purge the duct prior to appliance start-up and post-purge the duct for 3 minutes after appliance shut down.
- Set to run the fan continuously.

In most cases, local codes will require continuous fan operation.

Other functions The control has an integrated safety function. It can be operated with a manual reset function (reset button) or an automatic reset function. All terminal connections are monitored by LED's for easy service and troubleshooting.

Listings The **exodraft** MEC18 is tested and listed to the Standard for Industrial Control Equipment, UL Standard 508 and CSA C22.2 No. 14-10.

1.2 Shipping

Standard packing list

The MEC18 contains the following:

- MEC18 control unit
- Pressure transducer (XTP)
- Silicone tubing
- Duct probe
- Jumpers

If other components are shipped, these will appear as separate items on the shipment packing list.

2. Specifications

2.1 Dimensions and capacities

exodraft MEC18 control		
Power supply	V	1 x 120 V AC
Amperage	A	6.3
Operating temperature	°F/°C	-4 to 122/-20 to 50
Range of operation	inWC/Pa	0-0.6/0-150
Tolerance	inWC/Pa	0.01/3+/-10%
Output current	mA	max. 10
Max. load		120 V AC/8A
Output	V AC	10-120
	V DC	0-10
Dimensions	A in/mm	6.9/175
	B in/mm	8.1/205
	C in/mm	4.0/102
Weight	lbs/kg	3.0/1.5
EMC standard	Emission	EN50 081-1
	Immunity	EN50 082-2
XTP-sensor		
Power supply	V DC	0-24
Amperage	mA	<20
Output	V DC	0-10
Operating temperature	°F/°C	-4 to 140/-20 to 60
Tolerance	inWC/Pa	0.01/3+/-10%
Dimensions	D in/mm	1.93/49
	E in/mm	2.92/74
	F in/mm	3.63/92
	G in/mm	3.15/80
Weight	lbs/kg	.9/4
Duct probe		
Dimensions	H in/mm	4.25/108
	I in/mm	3.50/89

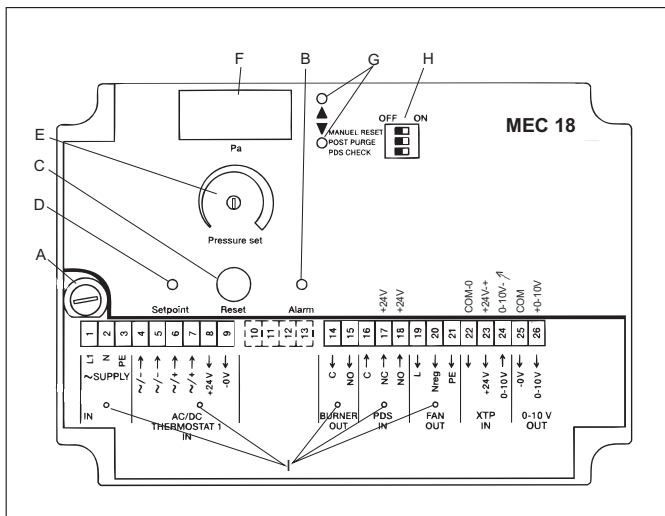
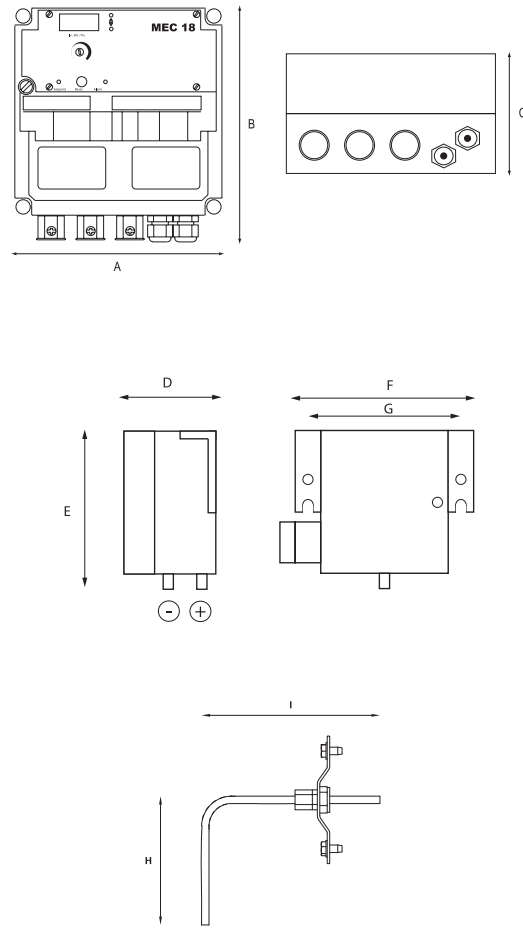

Fig. 1

Symbols:

- Fig. 1-A Fuse holder
- Fig. 1-B Alarm-red LED
- Fig. 1-C Reset button
- Fig. 1-D Set point button
- Fig. 1-E Potentiometer for pressure setting
- Fig. 1-F Display
- Fig. 1-G LEDs (yellow) showing increasing/decreasing speed
- Fig. 1-H Dipswitch block
- Fig. 1-I LEDs (green) showing ON/OFF status

3. Mechanical installation

3.1 Location



The control and transducer must be installed indoors. The control does not need to be installed in an enclosure. See fig. 2 for component connections.

The transducer cannot be mounted inside an airtight enclosure. It uses the atmospheric pressure as reference pressure.

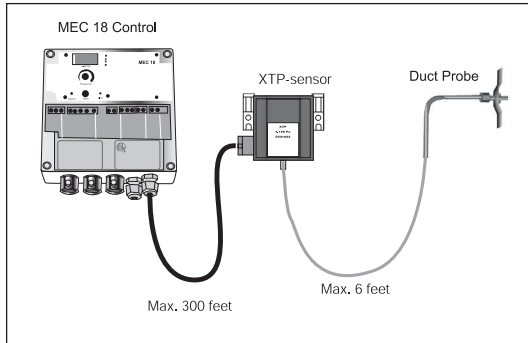

Fig. 2

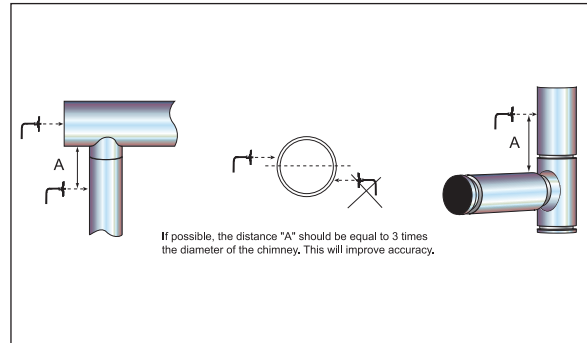

Fig. 2a

3.2 Mounting of control

The control can be mounted directly to a wall or similar. Remove the cover. The mounting holes are located under the plastic screws that hold the cover in place. See fig. 3.

The distance between the control and the transducer should not exceed three hundred (300) feet.

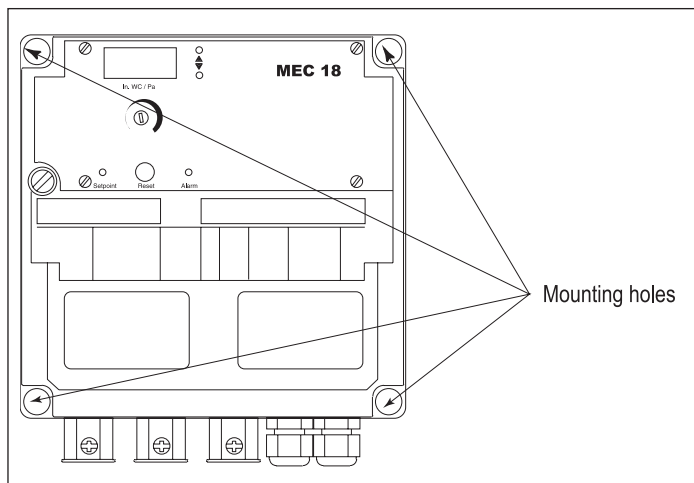

Fig. 3

3.3 Mounting of transducer

Attention must be paid to the position and location of the transducer. Fig. 4 shows the required position. Failure to follow this instruction may result in an inoperable system.

The transducer should be mounted within six (6) feet of the duct probe.

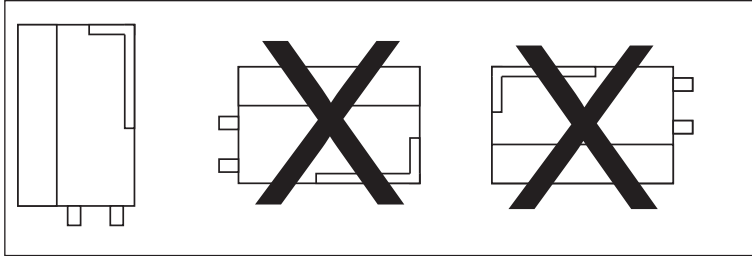

Fig. 4

3.4 Mounting of duct probe

The probe (fig. 2a on page 5) is inserted into the duct or vent at a point where the pressure is kept constant.

This could be at the appliance outlet, in the common duct or similar.

Make sure the tip of the tube is flush with the inner wall of the duct. Protrusion into the duct may affect the reading and thereby the operation.

3.5 Connecting transducer to duct probe

The transducer (XTP) is connected to the duct probe via a silicone tube. Connect one end of the silicone tubing to the duct probe and the other end to the NEGATIVE port of the transducer as shown in fig. 5.

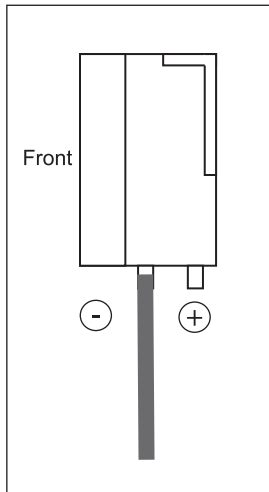

Fig. 5

4. Electrical installation

4.1 General



Danger:

Turn off electrical power before servicing. Contact with live electric components can cause shock or death.



MEC18 is designed for a 1 x 120 V AC power supply only. Fan output is regulated on the neutral side and cannot be connected to other circuits.

The control can be used in one of two ways:

- Interlocked with an appliance so the appliance operation indirectly controls the fan operation (see Chapter 4.2).
NOTE: This option is not available when used with a VFD.
- Connected so the fan runs continuously independent of appliance operation (see Chapter 4.3).

In both cases, the control monitors and maintains a constant pressure.

There are two types of safety systems available:

- Integrated Proven Pressure Switch (standard)
- Integrated Proven Pressure Switch with External Proven Pressure Switch (accessory) backup (see chapter 4.4).

The terminals are connected as shown on fig. 6:

Terminal	Use	Terminal	Use
1	Power Supply-L1	15	Appliance relay contact-Normally Open (max. 120 V AC, 8 Amps.)
2	Power Supply-N	16	PDS-C (Common) Proven Pressure Switch
3	Power Supply-Ground	17	PDS-NC (Normally Closed) Proven Pressure Switch
4-5	Voltage Input from Appliance thermostat Optocoupler (-) (10-120 V AC/DC)	18	PDS-NO (Normally Open) Proven Pressure Switch
6-7	Voltage Input from Appliance thermostat Optocoupler (+) (10-120 V AC/DC)	19	Fan-L1
8	24 V DC power supply to dry set of contacts (appliance thermostat)	20	Fan-N (regulating)
9	0 V DC power supply to dry set of contacts (appliance thermostat)	21	Fan-Ground
14	Appliance relay contact-Common (max. 120 V AC, 8 Amps.)	22	XTP-0 V DC Power Supply (transducer)
		23	XTP-24 V DC Power Supply (transducer)
		24	XTP-0-10 V DC Return Signal (transducer)
		25	Control signal 0 V DC
		26	Control signal 0-10 V DC

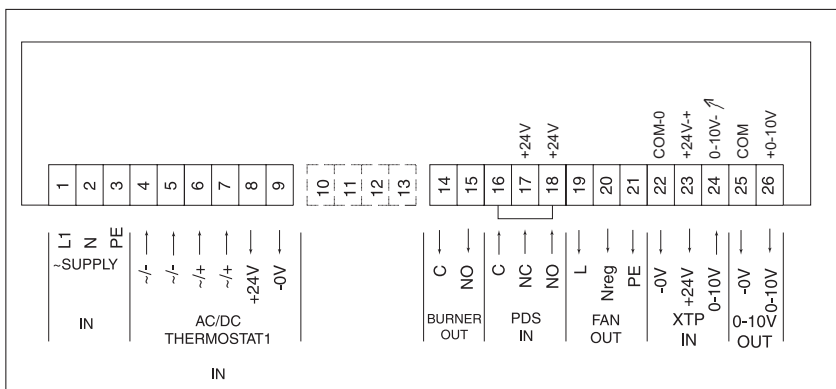

Fig. 6

4.2 Continuous fan operation

8

For continuous fan operation, connect the fan to the control as described below.

- Connect a 1 x 120 V AC power supply to terminals 1, 2 and 3
- Jump terminals 5 and 9
- Jump terminals 6 and 8.
- Connect the appliance:
 - ♦ Connect the start signal from the appliance to terminals 14 and 15.
- Connect the fan:
 - ♦ If using a 1 x 120 V fan, connect it to terminals 19, 20 and 21. Refer fig. 7 and the fan's installation manual
 - ♦ If using a 3-phase fan and VFD, connect the VFD to terminals 25 and 26 as shown in fig. 10 and 11
 - ♦ **DO NOT** connect the fan directly to the MEC18 control
 - ♦ Connect the transducer (XTP) to terminals 22, 23 and 24.

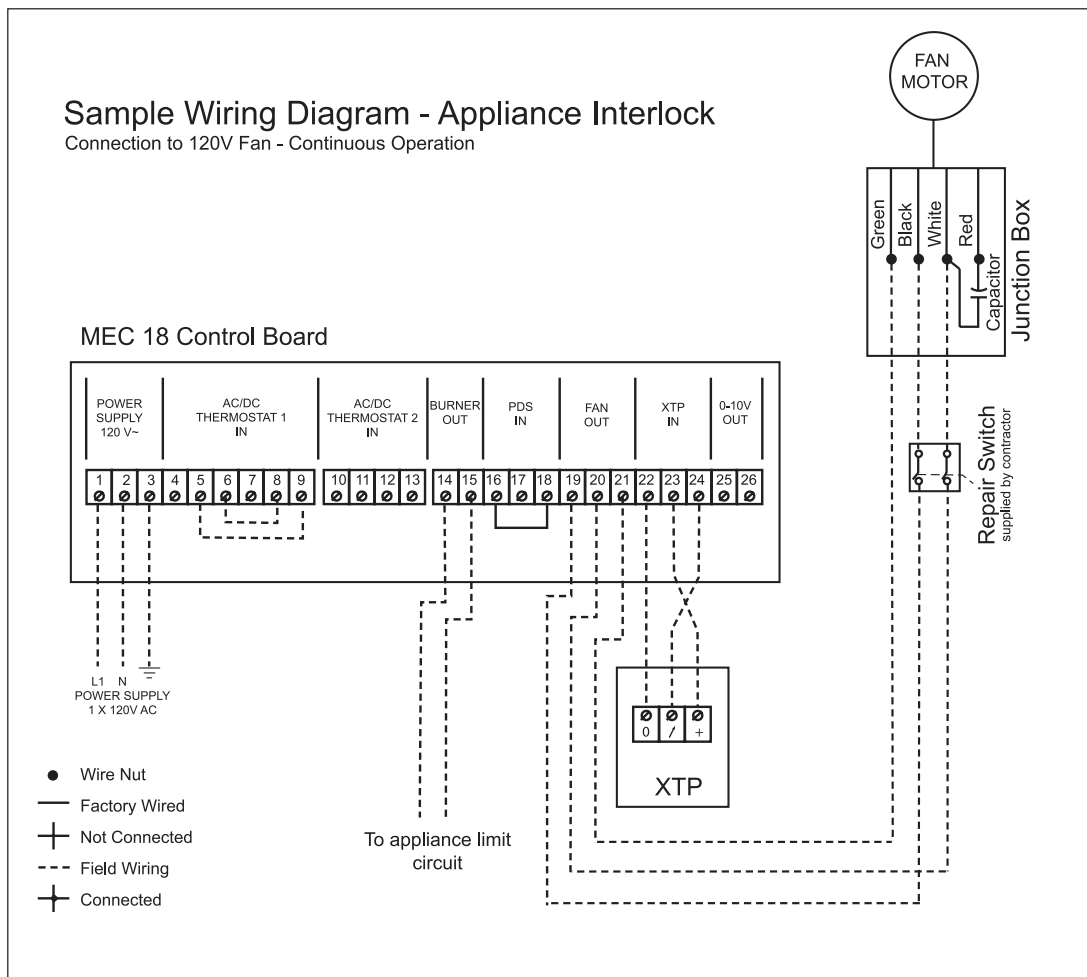

Fig. 7

4.3 Intermittent fan operation

The control can be set up for intermittent operation in one of two ways:
It can be interlocked directly with the appliance control or with a dry set of contacts.

Interlock with appliance

Fig. 8 shows how an appliance control signal (10-120 V AC/DC) is connected to the MEC18:

- Connect the power supply to terminals 1, 2 and 3
- Connect the appliance:
 - ♦ Connect the appliance start signal to terminal 4
 - ♦ Jump terminals 5 and 14
 - ♦ The start signal to the appliance is now activated by terminal 15
 - ♦ Connect Neutral to terminal 6.
- Connect the fan:
 - ♦ If using a 1 x 120 V fan, connect the fan to terminals 19, 20 and 21. Make sure the neutral line is dedicated to the fan and control (term. 20) only. Refer to the fan's installation manual.
 - ♦ If using a 3-phase fan and VFD, connect the VFD to terminals 25 and 26 as shown in fig. 10 and 11
 - ♦ **DO NOT** connect the fan directly to the MEC18 control
 - ♦ Connect the transducer (XTP) to terminals 22, 23 and 24.

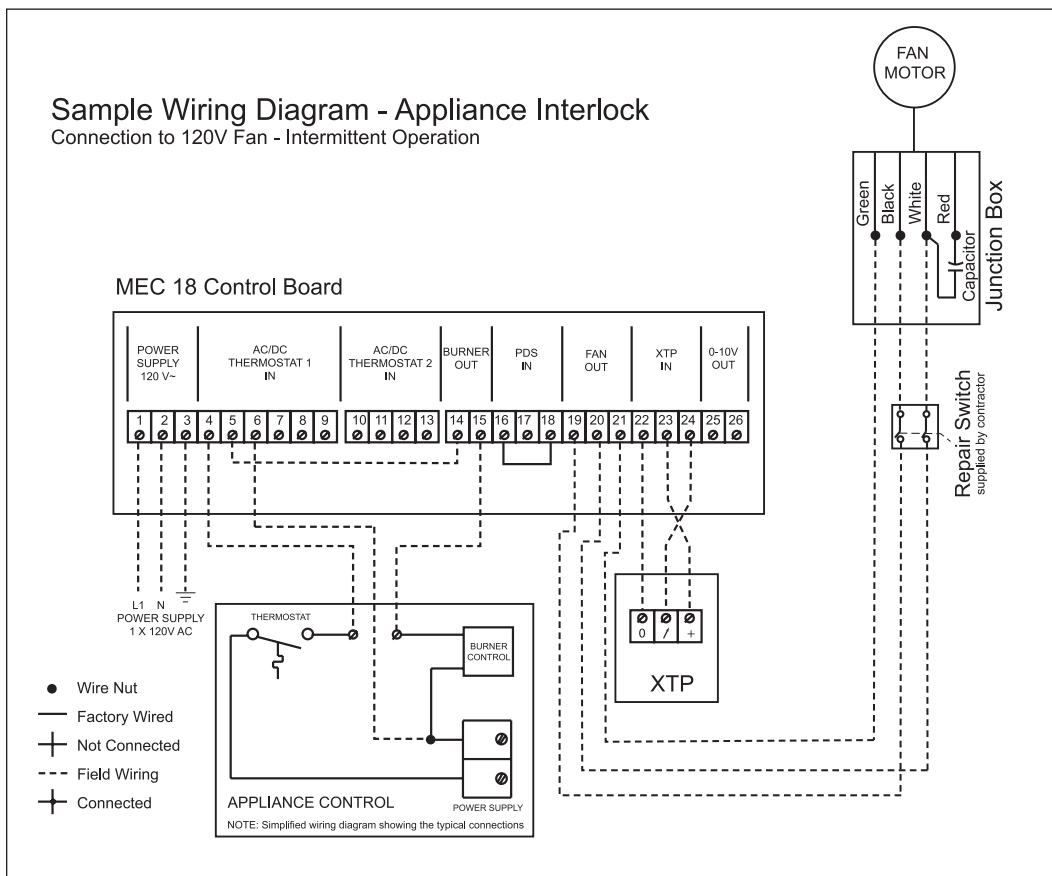

Fig. 8

Interlock with dry set of contacts

10 Fig. 9 shows how a dry set of contacts is connected to the MEC18:

- Connect the power supply to terminals 1, 2 and 3
- Connect the appliance:
 - ♦ Connect the dry set of contacts to terminals 6 and 8
 - ♦ Jump terminals 4 and 9
 - ♦ Connect the start signal to the appliance to terminals 14 and 15.
- Connect the fan:
 - ♦ If using a 1 x 120 V fan, connect the ventilator or fan to terminals 19, 20 and 21. Refer to the fan's installation manual
 - ♦ If using a 3-phase fan and VFD, connect the VFD to terminals 25 and 26 as shown in fig. 10 and 11
 - ♦ **DO NOT** connect the fan directly to the MEC18 control
 - ♦ Connect the XTP transducer to terminals 22, 23 and 24.

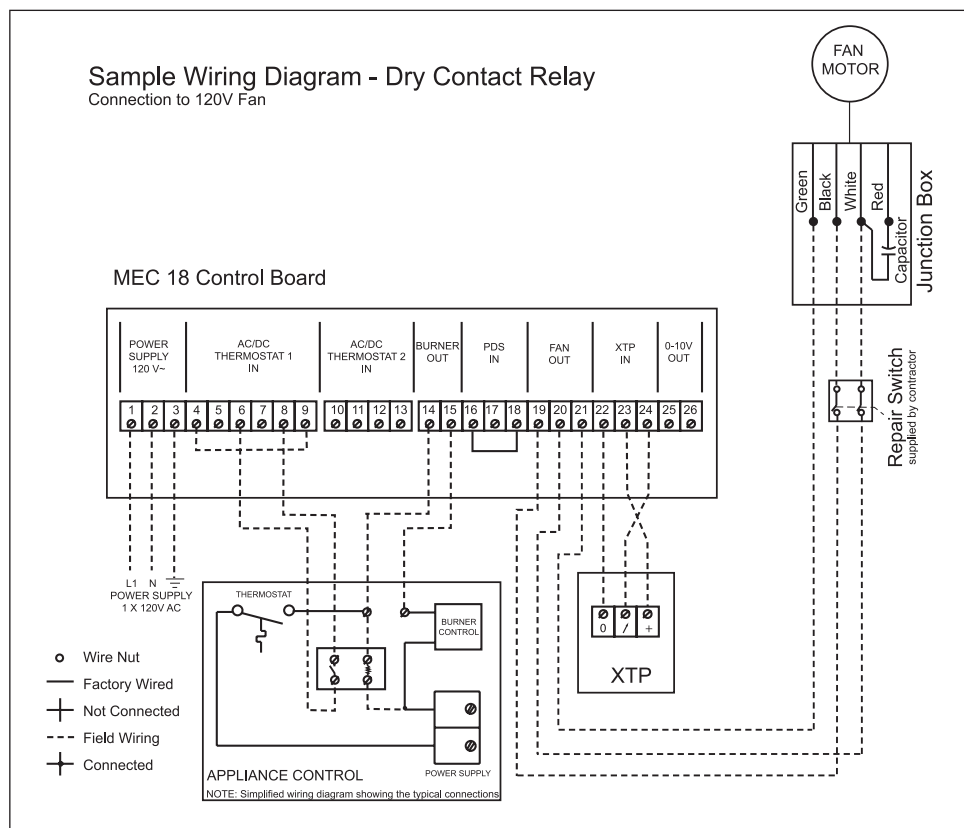

Fig. 9

4.4 Connection to a Variable Frequency Drive

To connect the 3-phase fan and variable frequency drive (VFD), connect the VFD to terminals 25 and 26 of the MEC18.

DO NOT connect the fan directly to the control.

Wire the ABB ACS320 series variable frequency drive according to fig. 10.

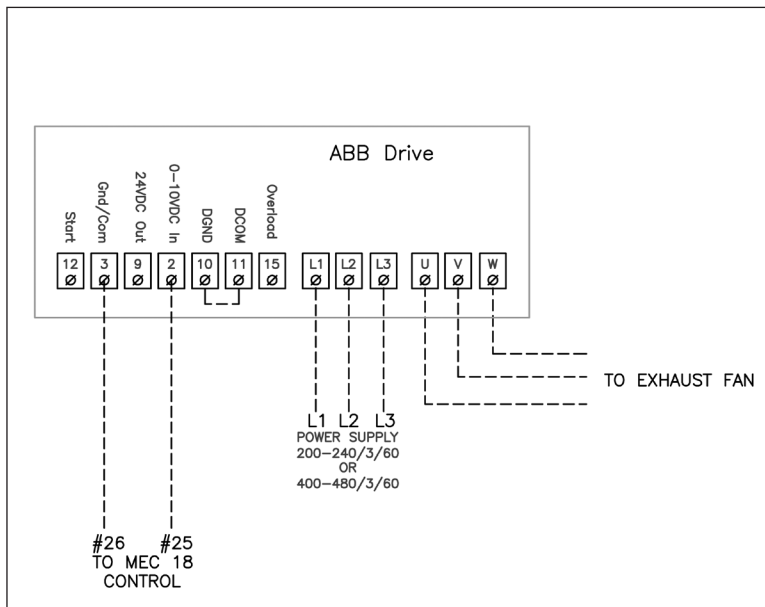

Fig. 10

Wire the VLT Micro Drive variable frequency drive according to fig. 11.

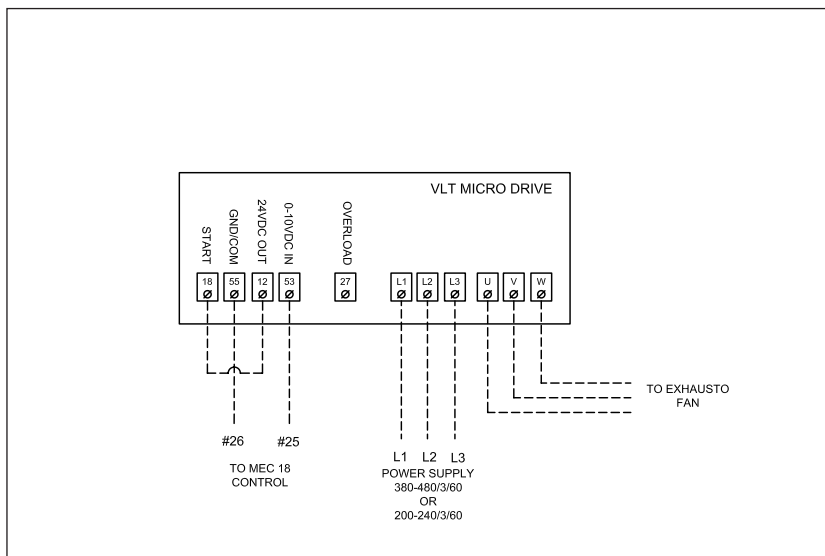

Fig. 11

4.5 Integrated with external PDS

12

Fig. 12 shows how to connect a external Proven Pressure Switch (PDS) to the MEC18. The external PDS is a backup to the integrated PDS and **both** must be satisfied by sufficient pressure to release the appliance:

- Remove the factory installed jumper over terminals 16 and 18.
- Connect the switch to terminals 16, 17 and 18 as shown in fig. 11.

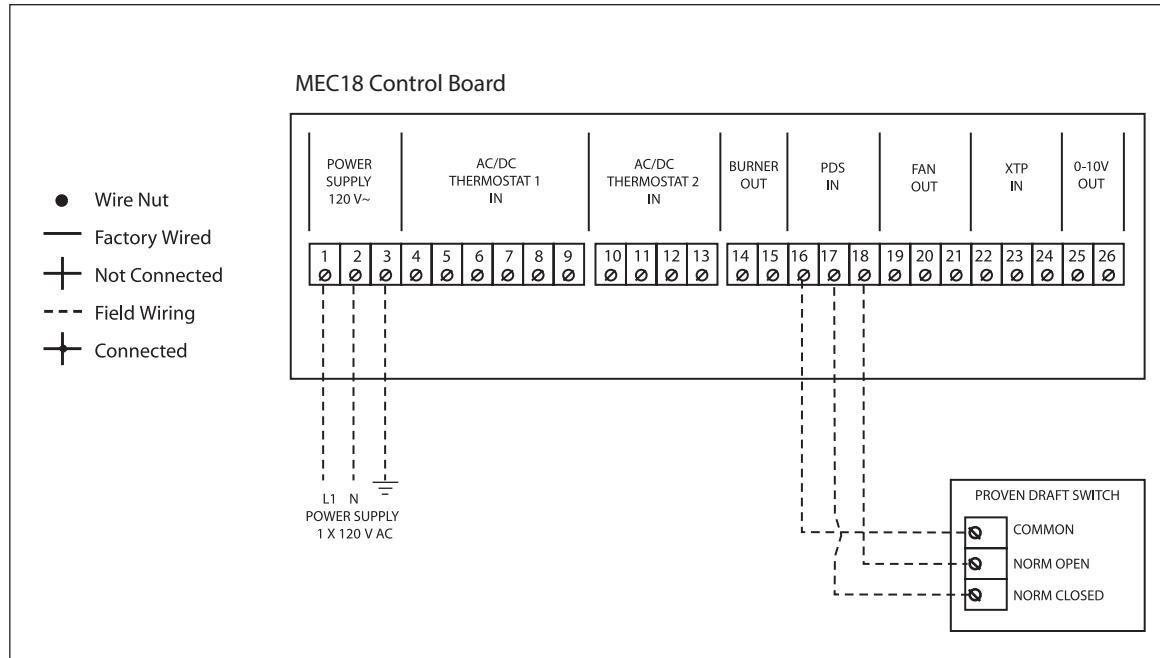

Fig. 12

5. Startup and configuration

5.1 General

Prior to start up please review the paragraph below titled Dipswitch settings.

Dipswitch settings

Prior to starting the system, check to see if the dipswitch settings are as required:

- Default factory setting: All OFF
- If the factory setting must be changed, remove the black cover plate to gain access to the dipswitches
 1. Remove the potentiometer dial
 2. Remove the (4) flathead screws and lift the top plate off the board
 3. Change the dipswitch settings.

Dipswitch	Name	OFF	ON
1	MANUAL RESET	Automatic reset at power failure or insufficient pressure.	Manual reset at power failure or insufficient pressure.
2	POST PURGE	No post-purge.	3 minutes of post purge.
3*	PDS CHECK	No monitoring to see if the PDS was in NC position prior to start.	The PDS must be in NC prior to start.

* Always OFF if the Proven Pressure Switch (PDS) is not connected.

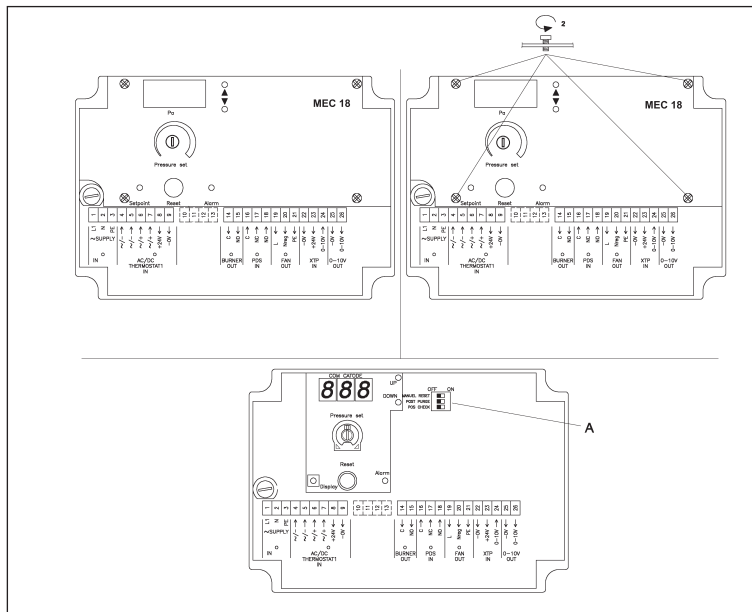

Fig. 12

5.2 Setting operating pressure

14

The pressure setting of the MEC18 must be adjusted to assure proper pressure for the appliance. The display (fig. 13-C) has two functions. It shows what the pressure set-point is, and it shows what the actual pressure is. The default mode shows the actual pressure. To change the mode, the set-point button must be pressed continuously.

To adjust the pressure set-point follow this procedure:

Temporary adjustment

1. Press the set-point button continuously with a pen or screwdriver (fig. 13-A) until the pressure setting appears on the display. While continuing to press the set-point button, use the potentiometer (fig. 13-B) to set the required pressure in WC/Pa on the display (fig. 13-C). Release the set-point button; the actual pressure will now show up on the display.
2. Start the heating system and wait until the thermostat (fig. 14-A) closes and the pressure has stabilized (none of the yellow diodes are lit).

Final adjustment

3. Check the pressure at the appliance outlets and make any necessary adjustment by following the procedure described under step 1 above.
4. If used, check that the safety system disconnects the appliance (fig. 14-B). An error can be simulated by disconnecting the silicone tubing from the negative port on the transducer (XTP).
5. Check the start function after the final pressure setting adjustments have been made.

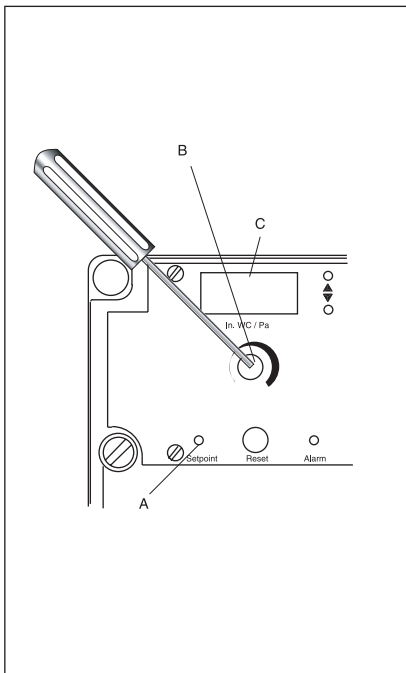

Fig. 13

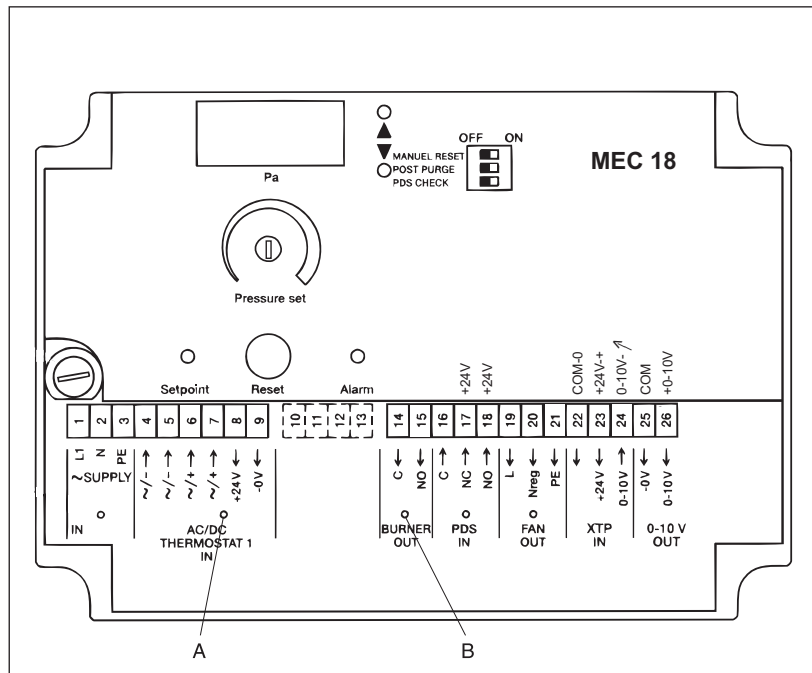

Fig. 14

6. Maintenance and troubleshooting

Observation	Problem	Solution
No light in the SUPPLY diode (fig 15-A)	Blown fuse or interrupted power supply	1) Check the fuse (fig. 15-B) and the fan power. 2) Check the power supply.
Constant light in "Increasing Speed" diode (fig 15-E)	System fault	1) Check that the probe is connected to the "-" port on the XTP transducer. 2) Check that the probe is not clogged. CAUTION: Do not blow into the XTP-transducer. 3) Check that the fan is running. 4) Set-point is too high for the fan capacity. Check/reduce setting. 5) Check the entire system's adjustment, including any balancing baffles installed. 6) Check duct for leakages. 7) Check the power supply to the XTP.
Constant light in "Decreasing Speed" diode (fig 15-D)	System fault	1) The natural stack effect prevents the system from reaching the set-point. Check the adjustment. If necessary, install a balancing baffle or other resistance in the duct. 2) The probe may be in a bad location.
Constant light in ALARM diode (fig. 15-H), but no light in FAN diode (fig. 15-G) (Can only occur when MANUAL RESET is ON (fig. 15-F))	Power outage	Press the RESET button (fig. 15-C) for (1) second — see warning.
Constant light in Alarm diode and light in fan diode (fig. 15-H)	Insufficient pressure	1) Press the RESET button (fig. 15-C) — see warning. 2) Check that the service disconnect switch is working properly. 3) Check the connectors, chimney and fan for blocking restrictions.
Flashing ALARM diode (fig. 15-H) Can only occur when PDS CHECK is ON (fig. 15-F)	Error in safety system (PDS)	1) Check that a PDS is installed. 2) Check the setting of the safety system (the natural stack effect can prevent close/alternatively the PDS CHECK dipswitch can be moved to its OFF position. 3) Check the connection to the PDS and the PDS itself.
The MEC18 does not regulate and the fan is running at full speed	The neutral connection is shared with other devices.	1) Check the amp-draw on terminal Nreg. If it is "0", the neutral connection to the fan is being shared.



Some appliances require a certain startup procedure after a shutdown. Follow this procedure prior to pressing the RESET button (fig. 15-C).

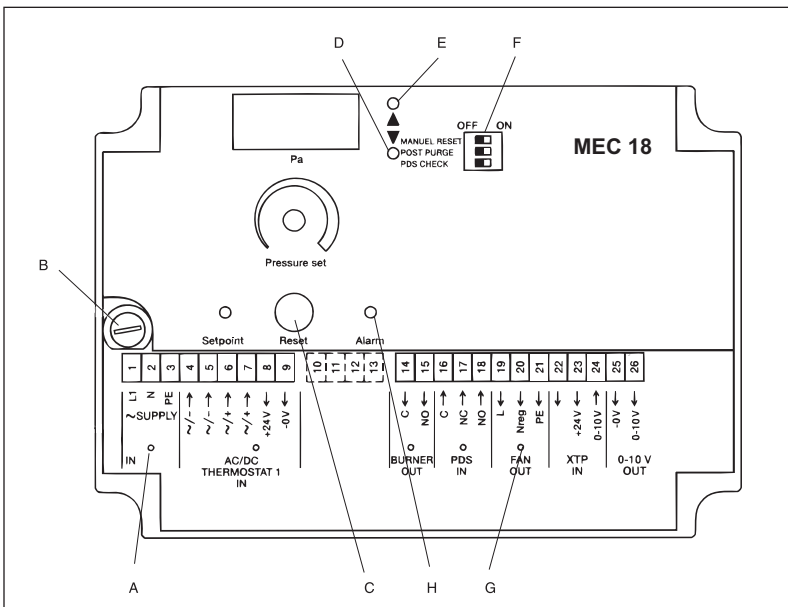

Fig. 15

